

Big Chamber Water Hammer Arrestor

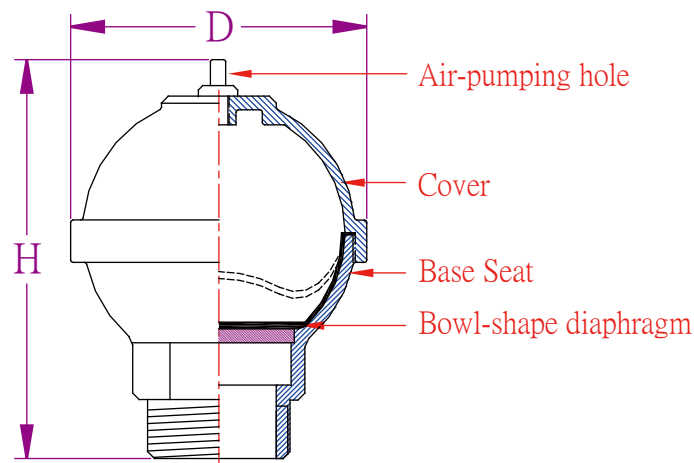

- ★ Applied Condition : Water
- ★ Applied Temperature : 0 °C ~ 60 °C
- ★ Vertical and horizontal installation is acceptable.
- ★ Diaphragm Rubber : NBR
- ▼ Body material : Stainless Steel CF8
- ▼ Body Testing Pressure / Working Pressure
16 kgf/cm² / 10 kgf/cm²



Model : APT
(Threaded)

Size	H	D
1/2"	108	77
3/4"	109	77
1"	111	77

Unit : mm

★ The product doesn't have gauge