

Media: air - Inert Gas
 Inlet Pressure: 30 Bar max
 Outlet Pressure: 0 to 20 Bar
 Media temp: -10°C to +60°C
 Ambient temp: -10°C to +60°C
 Mounting: Upright

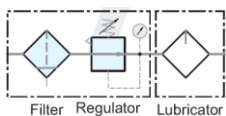

Stainless F R L

1/4 Miniature Series

316 Stainless Steel

Manual – Semi Auto Drain

0 – 30 Bar

TYPE SSFRL02



PRESSURE

Ø Port BSP	Max Flow Air L/min @ 6Bar (ANR)	Max Inlet Pressure (Bar)	Outlet Pressure (Bar)		Combination	Part Number
			Min	Max		
1/4	1850	30	0	20	Filter/Regulator + Lubricator	SSFRL600-02
	1850	30	0	20	Filter / Regulator	SSFR500-02
	1900	30	0	30	Filter	SSF200-02
	1850	30	0	20	Regulator	SSR200-02
	2500	20	0	20	Lubricator	SSL200-02

OPTIONS

5 Micron SUS316 Filter Element, Semi-Automatic drain, Pressure Gauge, Plug, Mounting Bracket, Screws
 Manual Drain (H)
 40 Micron SUS316 Filter Element
 NPT or Rc Thread
 Non relieving (Relieving is standard) **Included**

CONSTRUCTION

Body, Regulator, Filter (105cc) Lubricator (125cc), Filter Elements, Mounting Bracket, Blanking Plug: 316 Stainless Steel
 Pressure gauge: Case 304 Stainless Steel /Thread 316 Stainless Steel
 Test pressure: 30 Bar

OVERALL DIMENSIONS

SSFRL600 (2.66Kg)

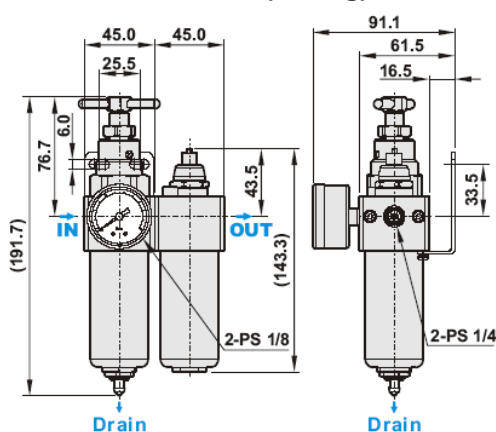

SSFR500 (1.38Kg)

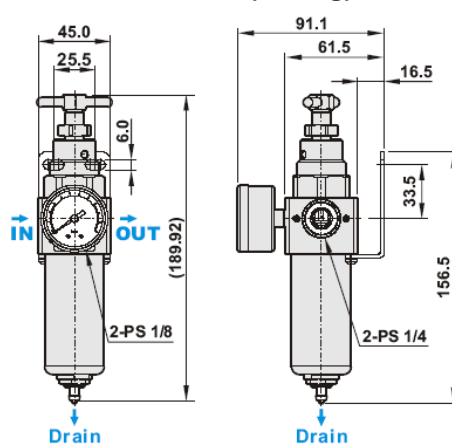

SSF200 (1.2Kg)

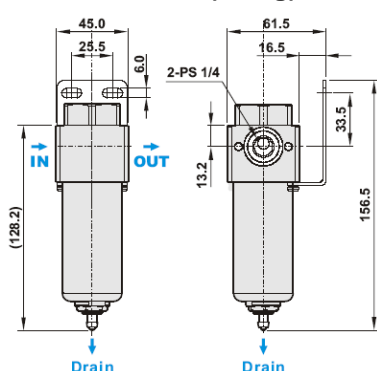

SSR200 (1.2Kg)

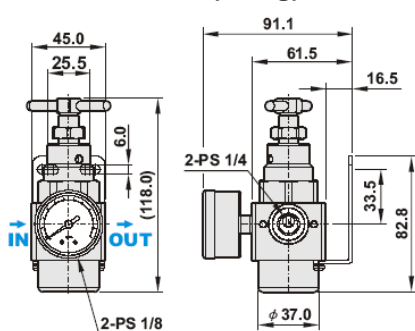

SSL200 (1.2Kg)

