

Ex e, t Connector Type 611-201-1317

 Approval no. nm 23.0001 X

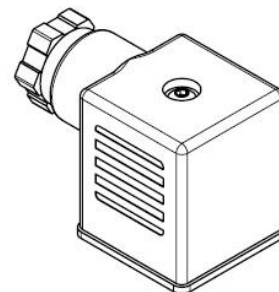

Operating Instructions

Dear Customer!

To ensure the function and for your safety, please read these operating instructions attentively before starting the installation. If you still have questions, please contact nass magnet.

Tel ++36 88 591-051
Fax ++36 88 591-075

 **www.nassmagnet.com**
e-mail info@nassmagnet.hu

General Conditions

- If these Operating Instructions are not followed or if unauthorized changes are made to the equipment, any manufacturer liability on our product will lapse. Our general terms and conditions apply.
- The Ex connector **Type 611-201-1317** is an equipment according to Directive 2014/34/EU, Art. 2.
- A correct installation to a counterpart (end device) is essential for the intended use and safe operation.
- The product complies with the standards stated in the certificate and the attached EU Declaration of Conformity. The explosion protection marking is as follows:

Gas: II 3 G Ex ec IIC T5 Gc

Dust: II 3 D Ex tc IIIC T100°C Dc

The equipment protection level (EPL) Gc allows use in Zone 2 or EPL Dc in Zone 22.

- Be sure to follow these Operating Instructions and the regulations applicable at the place of use. If in doubt, seek qualified advice!

Specific conditions of use for explosion protection

- The equipment is marked with the symbol “X” and thus refers to the special conditions of use that must be adhered to as follows (as well listed in the certificate):
- 1) “X”: Install only in areas with a low level of mechanical danger (ref. EN 60079-0, 26.4.2 Resistance to impact). The connector may only be mounted to equipment such as solenoid coils of the nass magnet portfolio that is centrally fastened on a cylindrical valve guide as to realise the same load case as tested.

- 2) "X": The installation location of the connector must be protected from light (ref. EN IEC 60079-0, 7.3 Resistance to ultraviolet light).
- 3) "X": The installation shall provide for a strain relief for the cable in close proximity of the connector to ensure that strain and torsion are not transmitted to the connector.
- 4) "X": The accessibility of the electrical connection for checking during operation must be ensured and maintained by the installation in the field.
- 5) "X": The connector may only be removed or opened from the connected counterpart when it is in a de-energised state!
- 6) "X": The connector is suited for an upper ambient temperature, which results from either the maximum temperature of the surrounding atmosphere or the maximum operating temperature of the connected equipment at the interface to the connector, whichever is higher. This value is called "interface temperature" and is limited, corresponding to the permissible current carrying capacity according to the diagram (contained in the Operating Instructions and offer drawing).
- 7) "X": The marked required degree of protection (IP) is only achieved with properly installed ports. For this purpose, the associated parts supplied must be used and the prescribed tightening torques must be observed.

Installation

- At installation and maintenance, it is essential to observe applicable standards for electrical safety and electrical installations in potentially explosive atmospheres, especially EN 60079-14.
- Be sure to observe the previous section "Specific conditions of use"!
- It is strictly required that the potential current consumption and interface temperature of the equipment to be connected is within the permissible limits of the connector.

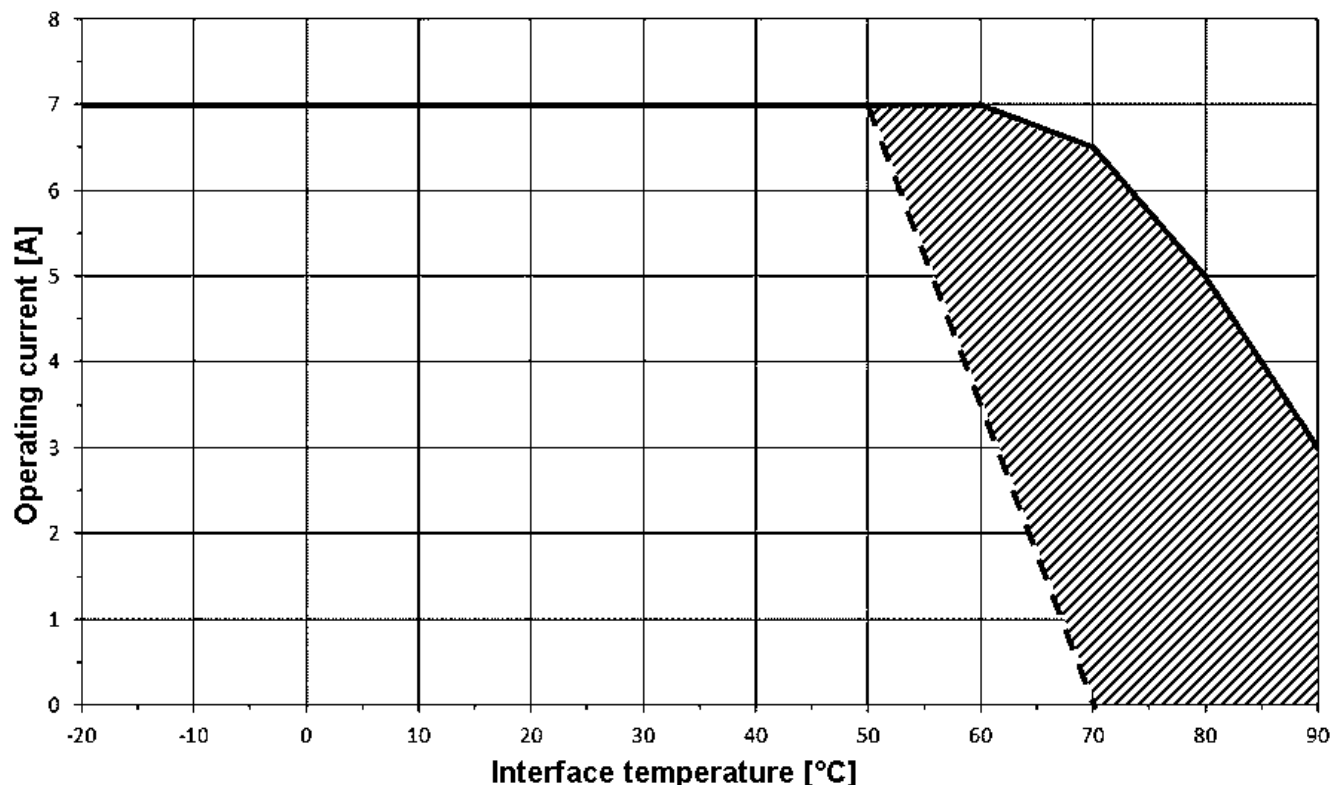

Observe therefore the current limit as a function of interface temperature as shown in the diagram above (drawn line, “derating”).

- The interface temperature represents either the ambient temperature of the connector or the operating temperature of the connected equipment at the interface to the connector respectively, whichever the greater. (Remark: in most cases the operating temperature of the equipment is greater than or equal to the ambient temperature). The indicated current limit takes into account a contact resistance in the contact area of up to 15 mohms per contact (see Technical Data).
- In the case of block mounting (connectors in series, wall-to-wall), it should be considered that the interface temperature is higher than with a single unit.
- The connected equipment’s operating temperature at the interface to the connector must not be higher than 90°C as not to overload the materials of the connector and as not to exceed the Ex Temperature Classification (surface temperature) of T5/100°C.
- Consider the previously determined values at choice of suitable cables and lines. At operating points within the shaded area, the temperature at the cable gland or wire branching point will be higher than 70°C or 80°C respectively.
- After removing the packaging, make sure that no dirt gets into the system. The wire ends must be free from dirt and corrosion.
- Make sure that seals and gasket do not get damaged during assembly.
- The cable gland is suited for cable diameters of 4 to 6 mm or 6 to 8 mm, one gasket ring provided for each range. Only one of them may be installed at a time.
- Observe the rated values of the cable corresponding to the respective requirements and ambient conditions at the point of wiring (see EN 60079-14). Prevent the cable and wires from being damaged.
- The installation shall provide for a strain relief in close proximity of the connector to ensure that strain and torsion are not transmitted to the connector.
- The rated conductor cross section may range from 0.5 mm² to 1.5 mm². The tightening torque of the clamp screw is 0.2 to 0.3 Nm.
- Stranded and fine-stranded conductors with ferrules or solid conductors may be used. The wire ends must be properly mounted into the terminals and must not be damaged. When using ferrules, observe the relevant documentation regarding the correct installation, in particular the suitable conductor diameters and the required stripping length. Observe the recommended stripping lengths when using solid conductors (see Sketch). Only one wire end may be used for each clamp. Soldering of stranded and fine-stranded wire ends is not permitted.

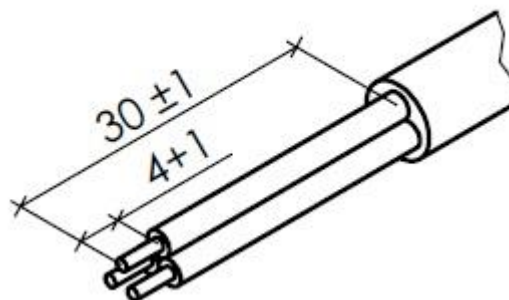

Stripping of solid conductors and stripping of the outer sheath

- Mounting is admissible in any position. The terminal block can be mounted inside the connector housing when offset in steps of 90° (see Assembly Sketch). No further settings are possible.

- Enclosure protection IP65 is attained with properly assembled ports. In this regard, observe the indicated seals and the required tightening torque of the fastening screw and the pressure screw.
- **Only use original spare parts provided by nass magnet, the ATEX attestation of conformity is no longer applicable to modified equipment.**

Assembly Sketch

- (1) Terminal block
with screw clamp contacts (2+PE)
tightening torque 0.2 to 0.3 Nm
- (2) Housing with gland thread M16
- (3) Fastening screw with sealing washer
hexagon socket SW2
tightening torque 0.4 ± 0.1 Nm
- (4) Gasket rings
1 pc for cable diameter 4 to 6 mm
1 pc for cable diameter 6 to 8 mm
- (5) Cable clamping ring
- (6) Pressure screw, thread M16
hexagon head, width 17 mm
tightening torque 1.8 ± 0.2 Nm
- (7) Flat gasket

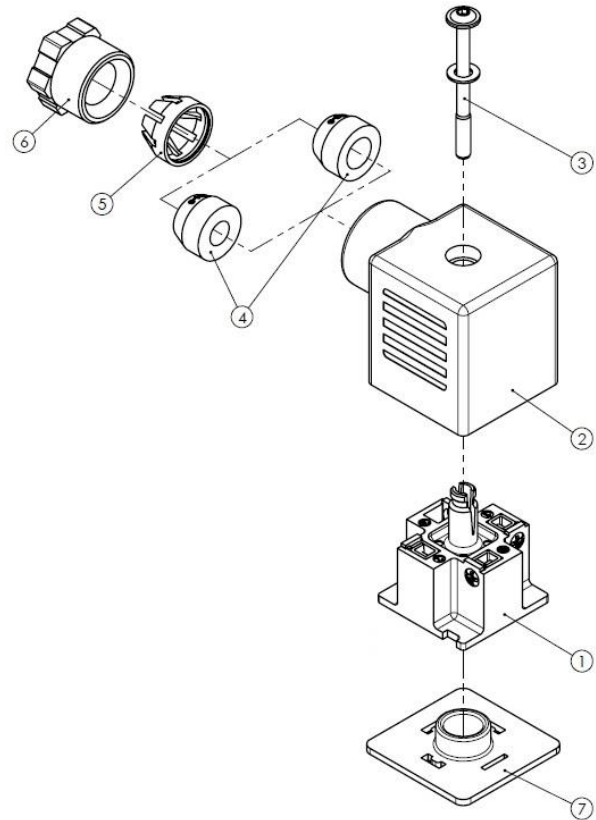

Initial start-up

- Check that all connections have been mounted correctly before initial operation.

Operation

Caution! Danger of arcing! The connector may only be disconnected or opened when de-energised!

Caution! Risk of injury! The connected equipment can have very hot surfaces!

- The connector suited for an ambient temperature down to -20°C . For the upper ambient temperature special conditions apply as indicated in section "Installation".
- Prevent the connector's surfaces from getting in contact with liquid or corrosive media.
- Frequent occurrence of condensate can lead to critical accumulation of water, for which the rated IP65 protection class is not sufficient. Exposure to natural weather is generally not permitted.
- Do not strain the equipment by bending or torsion.
- Prevent the connecting cable from being buckled or damaged to avoid short circuits and interruptions.
- The accessibility of the electrical connection for checking during operation must be maintained by the installation in the field.

Maintenance, servicing

- In principle, the connector is maintenance-free. However, the sealing materials (HNBR) naturally age depending on the load. Plan inspection intervals accordingly if aggressive atmospheres or constantly high temperatures are present. Inspect both the seal on the strain relief and the flat seal to the end unit. Retighten the pressure screw and the fastening screw with the permitted torques.
- Please order spare parts by indicating the identification number provided on the connector. Only use original spare parts belonging to the equipment provided by nass magnet!

Troubleshooting, Repair

- At malfunctioning take the necessary safety measures needed in hazardous areas.
- In case of visible external damages or for further investigation the equipment must be put out of operation. Make sure that no voltage is applied to the connector then.
- Repairs are only permissible by replacement with associated original parts.

Technical Data

Type	611-201-1317
Marking of explosion protection	II 3 G Ex ec IIC T5 Gc / II 3 D Ex tc IIIC T100°C Dc
Rated voltage	250 V _{rms}
Type of voltage	AC or DC
Rated current	up to 7 Arms, temperature-dependent ⁽¹⁾
Contact resistance	less than 15 mOhm (each contact)
Interface temperature	-20 ... up to +90°C, current-dependent ⁽¹⁾
Degree of protection of enclosure	IP65 according to EN IEC 60079-0, EN 60529 ⁽²⁾

(1) The current-load capacity diagram (derating curve) must be accounted for.

(2) With properly assembled ports (see section "Installation") the indicated degree of protection is attained after temperature conditioning and impact test.

Further data shall be taken from the applicable offer drawing 611-201-1317.



EU Declaration of Conformity

This declaration of conformity is issued under the sole responsibility of the manufacturer:

nass magnet Hungária Kft.
Henger u. 2.
HU-8200 Veszprém, Hungary

Product, Type-number / Object of the declaration:

Connector Type 611-201-1317

The object of the declaration described above is in conformity with the relevant Community harmonisation legislation:

2014/34/EU

... relating to equipment and protective systems intended for use in potentially explosive atmospheres (recast of 26 February 2014)

2011/65/EU, with (EU) 2015/863 and (EU) 2018/741

on the restriction of the use of hazardous substances in electrical and electronic equipment (recast of 8 June 2011, modified 31 March 2015 and 1 March 2018)

The conformity assessment procedure was accomplished according to Directive 2014/34/EU Article 13 (1) c). The manufacturer has issued the approval number **nm 23.0001 X** therefor.

Relevant harmonised standards used and references to the specifications in relation to which conformity is declared:

EN IEC 60079-0:2018

Explosive atmospheres – Part 0: Equipment - General requirements

EN 60079-7:2015

Explosive atmospheres – Part 7: Equipment protection by increased safety “e”

EN 60079-31:2014

Explosive atmospheres – Part 31: Equipment dust ignition protection by enclosure “t”

EN IEC 63000:2018

Technical documentation for the assessment of electrical and electronic products with respect to the restriction of hazardous substances

EN 175301-803:2007

Detail Specification: Rectangular connectors – Flat contacts, 0,8 mm thickness, locking screw not detachable

EN 60529:2000

Degrees of protection provided by enclosures (IP-Code)

Signed for and on behalf of

nass magnet Hungária Kft., Veszprém, 01 October 2023

Patrick Oelkers
General Manager

